

Specification of: DD 18/18 142974 3F 8P 1V +SCT == 6N09N4

High performance centrifugal fan DD

Double width, double inlet (DWDI), direct drive, forward curved blades fan. Lap-jointed scroll made of galvanized steel (EN 10142), assembled through a high-technology roller-locked seaming. Straight cut off plate at fan discharge. Impeller with forward curved blades of galvanised steel plate, directly mounted on a conventional "Internal Rotor" motor for no transmission losses. Closed (IP 55) frame, three-phase, single speed motor, usable at 400 V, 50 Hz or 60 Hz. Maintenance free, integral vibration isolators, self aligning ball bearings. Dynamically balanced according to DIN ISO 21940-11. With mounted terminal box. Air performance ratings according to AMCA 210-99 (Fig. 12), UNI 10531 (Fig 30c and par. 29.2 f) and ISO 5801 (Fig. 69 c and par. 30.2 f).

Technical data of the fan: DD 18/18 142974 3F 8P 1V +SCT == 6N09N4

fulfills the ErP requirements 2015

Description	Value Dimension
Specified duty point	
Air flow rate (V)	18894 m ³ /h
Static pressure rise (dp _{fs})	18 Pa
Actual duty point	
Installation acc. DIN 24163 Part 1	B
Reference density (Rho1)	1.20 kg/m ³
Medium temperature (t)	20 C
Air flow rate (V)	19057 m ³ /h
Total pressure rise (dp _t)	256 Pa
Dynamic pressure at discharge (pd ₂)	237 Pa
Static pressure increase (dp _{fs})	18 Pa
Velocity at discharge area (c)	19.9 m/s
Fan weight	98 kg
A-weighted sound power level discharge/intake LwA ₁₇	-92 dB
Rated data	
Phase-Voltage-Frequency	3~230/400-50 V-Hz
Number of poles:	6
Motor rating (P _N)	3 kW
Rated motor speed (n _N)	700 min ⁻¹
Rated motor current (I _N)	21,4/12,4 A
operational limits	
Max. absorbed power (P _{1max})	6.929 kW
Temperature range of conveying medium (t _{min} ...t _{max})	-20...40 C
ErP-Data at best efficiency and density 1.20 kg/m³	
measurement- / efficiency category	B / total
design status of VSD	without VSD
overall efficiency (ETA _{opt})	46.5 %
achieved efficiency grade (N _{Et})	50.6
required efficiency grade in 2013 / 2015 (N)	42 / 49
Air flow rate (V _{opt})	8677 m ³ /h
pressure rise (dp _{opt})	441 Pa
Fan speed (n _{vopt})	731 min ⁻¹
motor power input (P _{1opt})	2.28 kW
specific ratio (d _{dpopt})	1.004

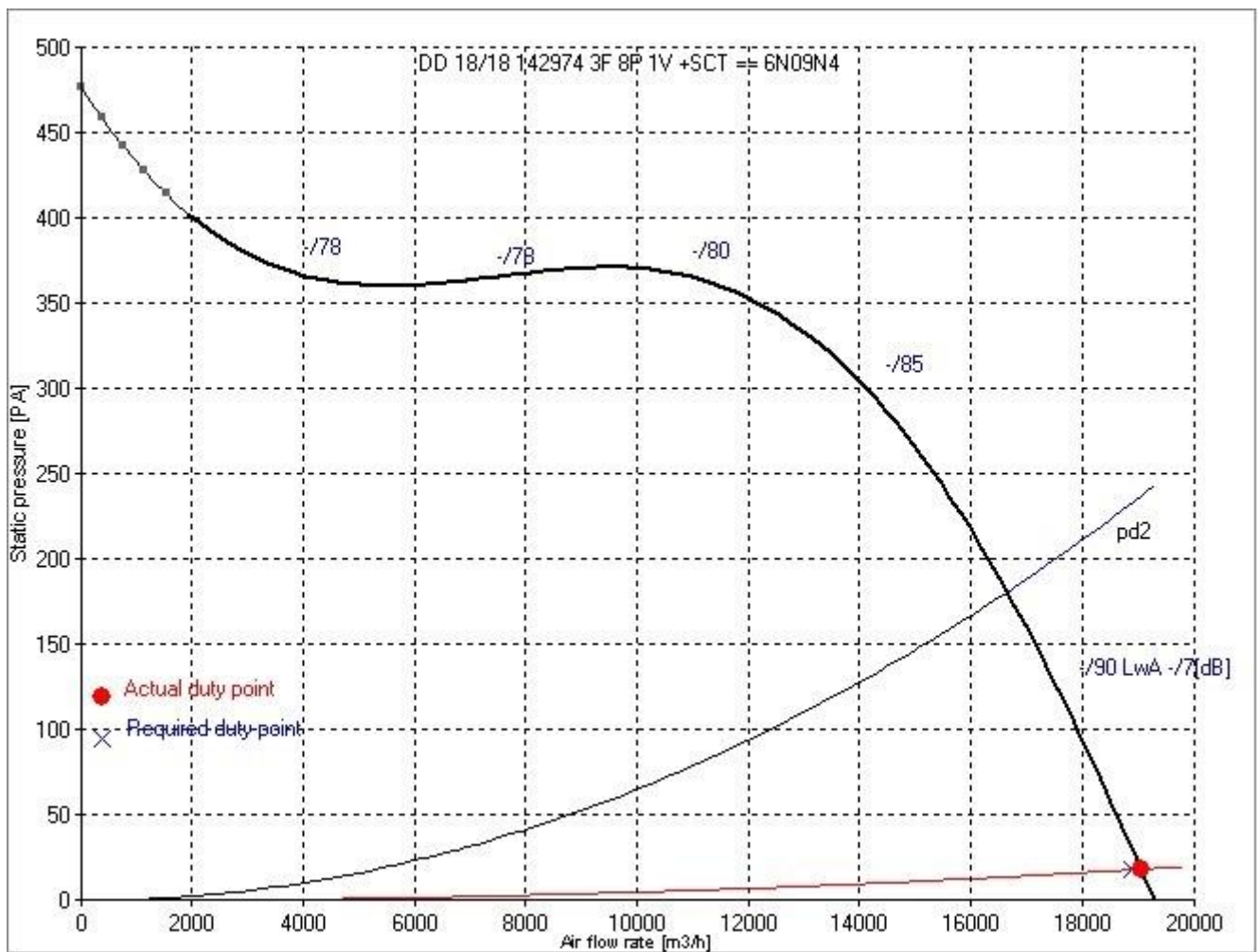

Dimensions

DD 18/18 142974 3F 8P 1V +SCT

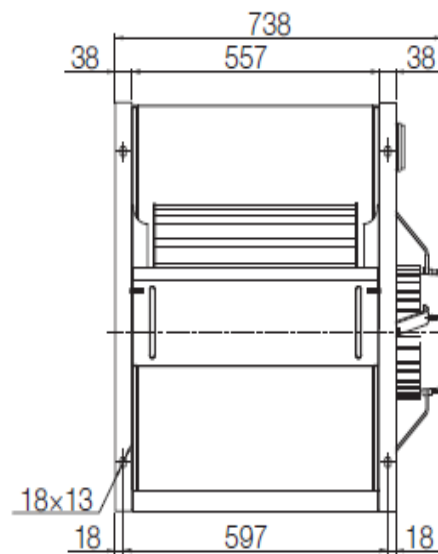
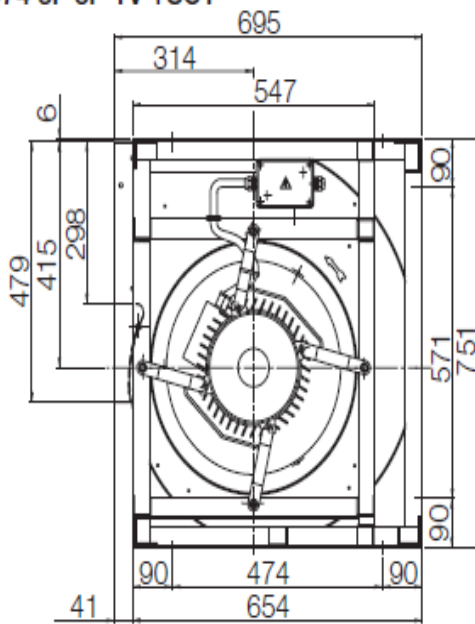

Rotation: RD
Handing: 90